

# Beam Kit / Rigid Truck Installation Instructions



## **Beam Kit / Rigid Truck Installation Instructions**

The details in this manual were correct at the time of printing. Bennett Engineering Ltd. reserves the right to enhance and modify specifications or designs without prior notice or obligation. For the latest updates or revisions, please contact Bennett Engineering Ltd.

**Bennett Engineering Ltd.**

**Horton Road**

**Horton**

**Chipping Sodbury**

**South Gloucestershire**

**England**

**BS37 6QH**

**01454 321707**

# Contents

---

Introduction .....	3
1 Truck Chassis .....	4
2 Preparation .....	5
3 Assembly.....	7
3.1 Back plate.....	7
3.2 Fork Slippers .....	7
3.3 Box Section and Gussets .....	8
3.4 Underrun Bar Assembly .....	9
3.5 Side Plates .....	10
3.6 60 X 10 Flat Bars .....	11
3.7 Cut to Size Supports .....	12
3.8 Ancillaries.....	13
3.9 Pull-Out Legs .....	14
3.10 Underrun Bar .....	15
4 Mounting the Forklift.....	17
5 Lighting Socket Wiring .....	18

## Introduction

---

The truck-mounted forklift is designed to be transported on the rear of a truck or trailer. You must read and understand this manual before fitting this mounting kit.

The purpose of this manual is to provide you with details on proper installation procedures for the Moffett mounting kit. The correct and most efficient installation procedure is explained and illustrated in this manual.

Before installing this mounting kit on your trailer, ensure that doing so will not void the manufacturer's warranty.

With the forklift on the back of your truck/trailer, the load distribution will have been altered. To ensure that the loading on the fifth wheel coupling (front axle on rigid vehicles) rear axles and the maximum vehicle dimensions are within the legal requirement for the country of use. Bennett Engineering Ltd. is available to address any queries and can perform these calculations.

All welders and fabricators of mounting kits should be certified to meet BSEN 283 and BSEN 288.

Unless specified otherwise, all welds should be 8 mm fillet welds.

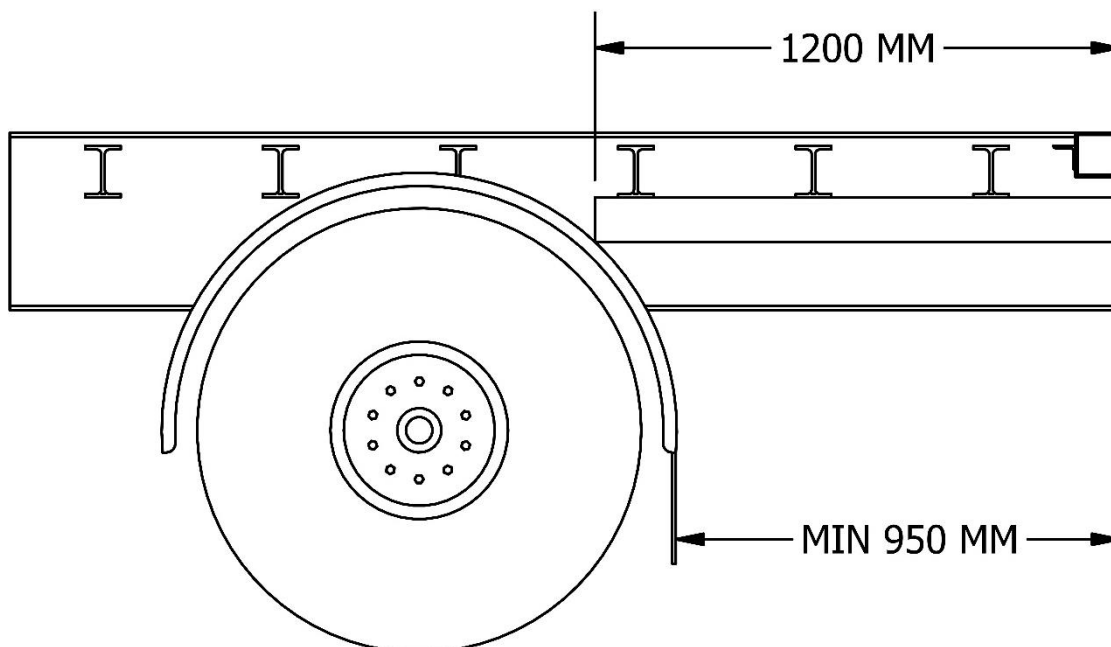
The chassis of most articulated trailers is made from mild steel, which allows the Bennett mounting kit to be welded without any adverse effects. However, the chassis of rigid trucks are made from high-tensile steel; in this case, it is advisable to use the bolt-on method to attach the mounting kit.

Existing holes in the chassis should be used whenever possible. If drilling is required, consult the truck or trailer manufacturer's documentation to ensure the warranty is not affected.

# 1 Truck Chassis

Before starting any of the following procedures, ensure that the following conditions are met:

1. The distance between the rear of the chassis and the nearest point of the rear wheel mudguards is at least 950 mm (Figure 1)
2. There is 1200 mm of space available for the fork slippers (Figure 1)
3. The rear cross member is in good condition
4. Manufacturers supply information to bodybuilders for body strength, construction etc. for rear-mounted cranes; this can also be used for truck-mounted forklifts
5. The forks do not interfere with any components around the rear axle, such as springs, airbags, anti-roll bars, air reservoirs, etc.
6. You are aware of your customer's preferred fork centre spacing
7. The curtain tensioners will not obstruct the mounting of the forklift
8. The trailer coupling on rigid trucks will not obstruct the fitting of the mounting kit
9. For special trailer or truck applications, it is important to contact Bennett Engineering Ltd.



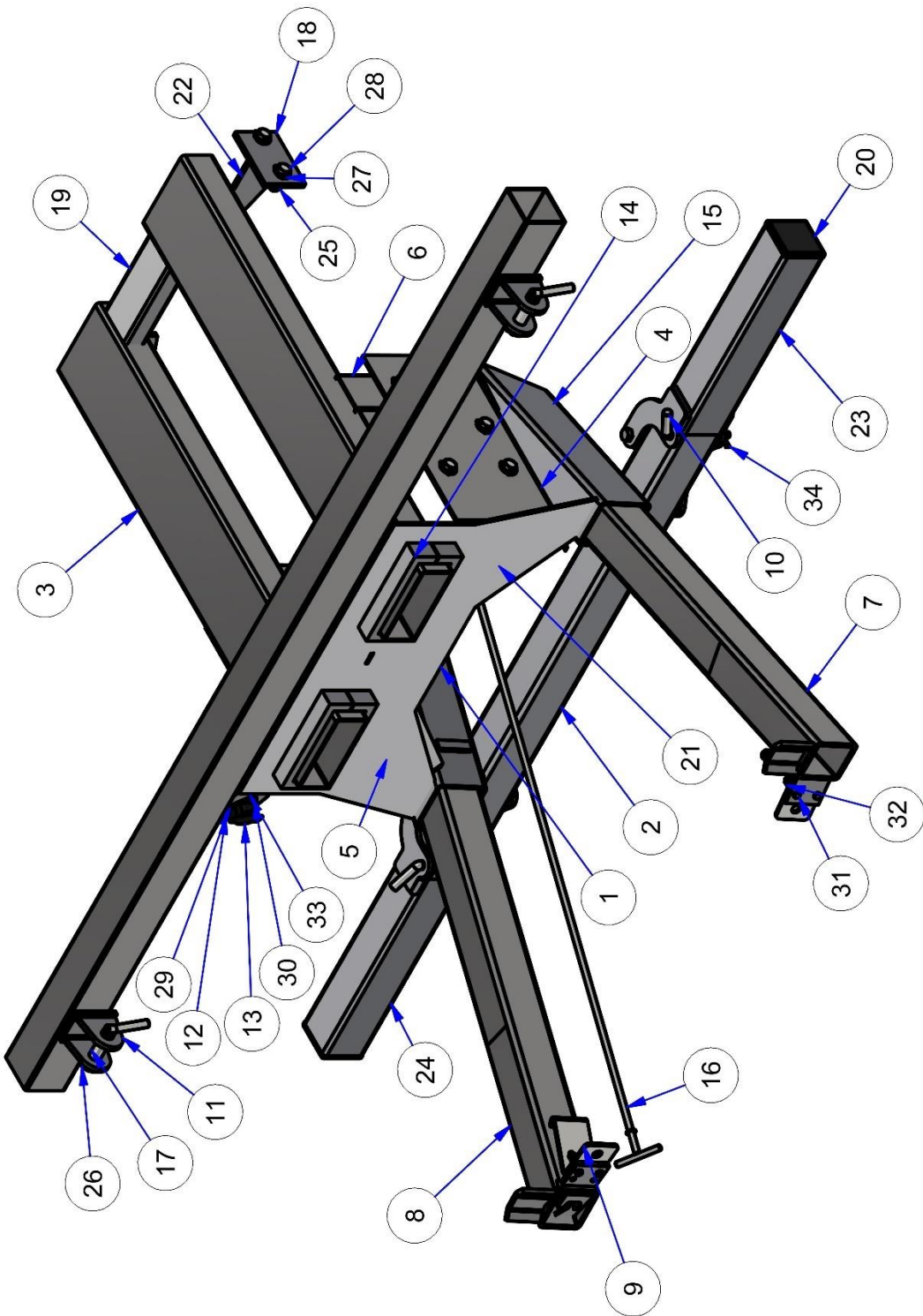
*Figure 1 (Chassis Check Dimensions)*

## 2 Preparation

1. To protect all electrical cables and light fittings during the assembly and welding of the mounting kit, remove them from the rear of the truck/trailer, extending as far back as the rear axle
2. Clean the chassis thoroughly and remove the existing crash bar
3. Before welding uncouple the tractor unit or disconnect the battery

**Table 1 (Parts List)**

Item	QTY	Part Number	Description
1	1	MKXXXX	Truck beam mount back plate
2	1	TMF010.010C	Centre underrun bar assembly
3	2	KA4001.01C	200 x 80 x 1200 fork tube
4	1	KASB010.09C	Chassis side plate RH
5	1	KASB010.11C	Chassis side plate LH
6	2	BP02553	100 x 100 x 4 truck BM support
7	1	HKA2003RH	Angled leg assembly RH
8	1	HKA2003LH	Angled leg assembly LH
9	2	KA2004.01	Catch
10	2	CTMK10.04C	Underrun bar pin
11	2	HBMK80.02C	Safety chain pin bracket
12	1	KASB010.08C	Light socket plate
13	1	KASOCK	Trailer light socket
14	4	KA4001.03C	Reinforcing plate
15	2	KA4001.04C	Leg retaining pin
16	1	KA3001	Leg pull handle
17	2	CTMK60.01C	Chain pin
18	2	KASB010.10C	Fork slipper bracket
19	1	BP02556	100 x 50 RHS cut to suit
20	2	ROTD15.OOC	100 x 100 plastic insert
21	2	BP02554	60 x 10 cut to suit bm truck
22	2	KASB010.12C	Fork slipper gusset
23	1	TMF010.03C	Underrun bar RH
24	1	TMF010.02C	Underrun bar LH
25	20	M16 NYLOCK	M16 Nylock nut
26	2	6 MM	Linch pin
27	32	BE-M16-THW	Hardened washer
28	20	M16 X 50 HB	Hex bolt 8.8
29	6	M8 HN	Nylock hex nut
30	2	M8 X 20	Hex bolt 8.8
31	4	M8 X 50	Bolt 8.8
32	4	KA2004.01S	Catch spring
33	2	M8 FW	Flat washer
34	4	R CLIP	



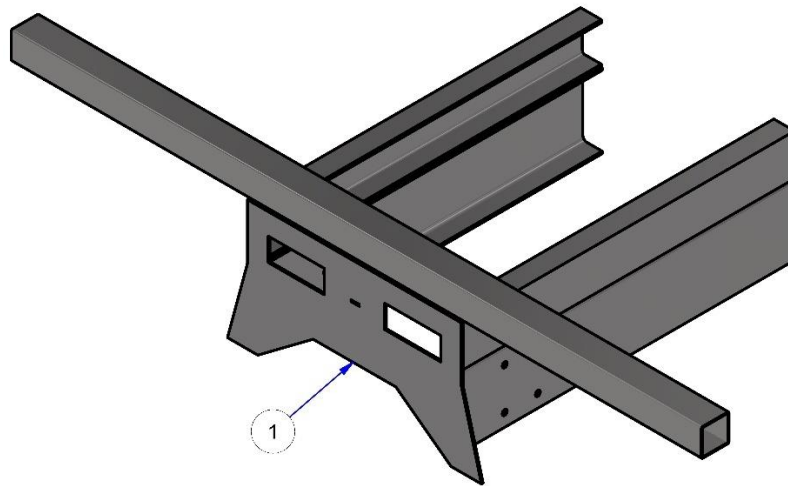
**Figure 2 (Complete Assembly)**

## 3 Assembly

---

### 3.1 Back plate

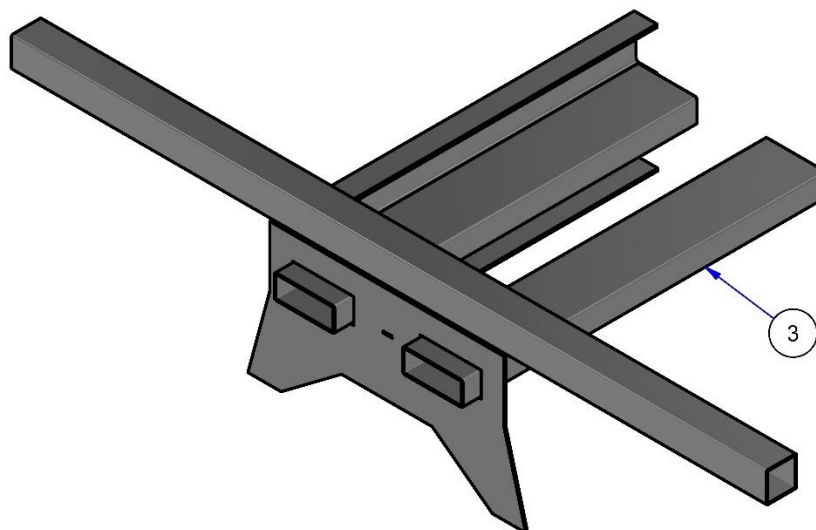
1. Tack weld the back plate centrally in place as shown in Figure 3
2. The design of the backplate is determined by the chassis configuration
3. A form should be filled out and the backplate made beforehand



*Figure 3 (Back Plate Positioning)*

### 3.2 Fork Slippers

1. Slide the fork slippers (200 x 80 x 1200 long RHS) into place through the fork pocket openings in the back plate as illustrated in Figure 4
2. Drill and bolt the fork slipper support gussets in position as shown in Figure 5

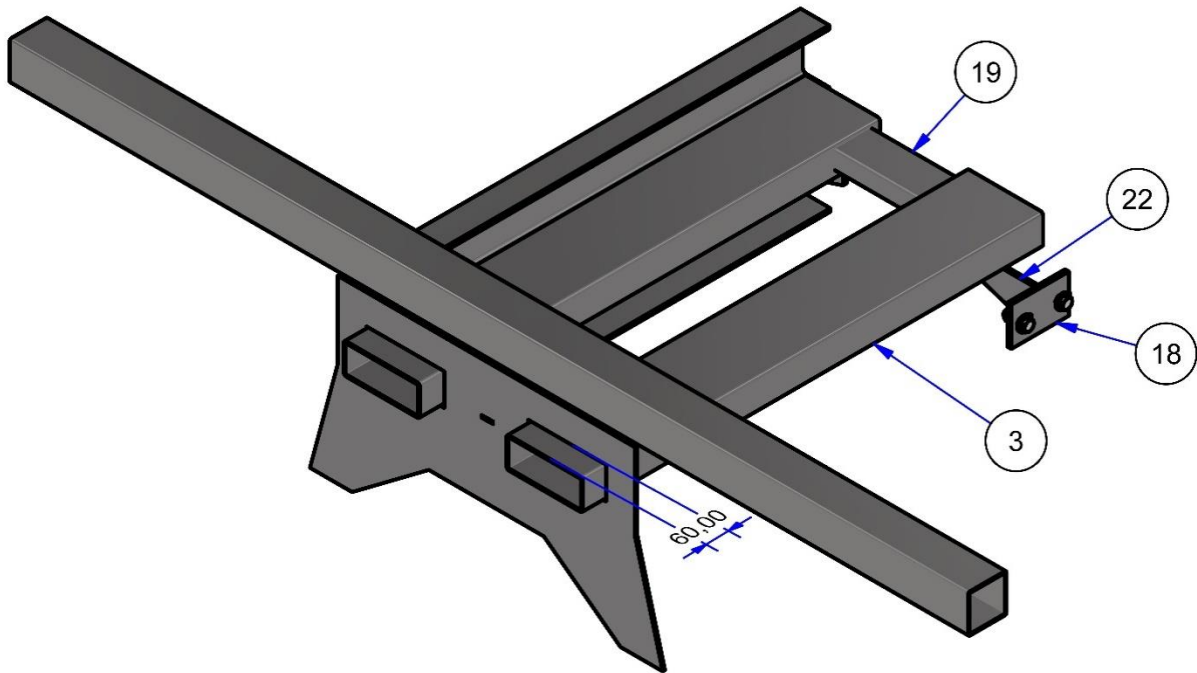


*Figure 4 (Fork Slippers)*

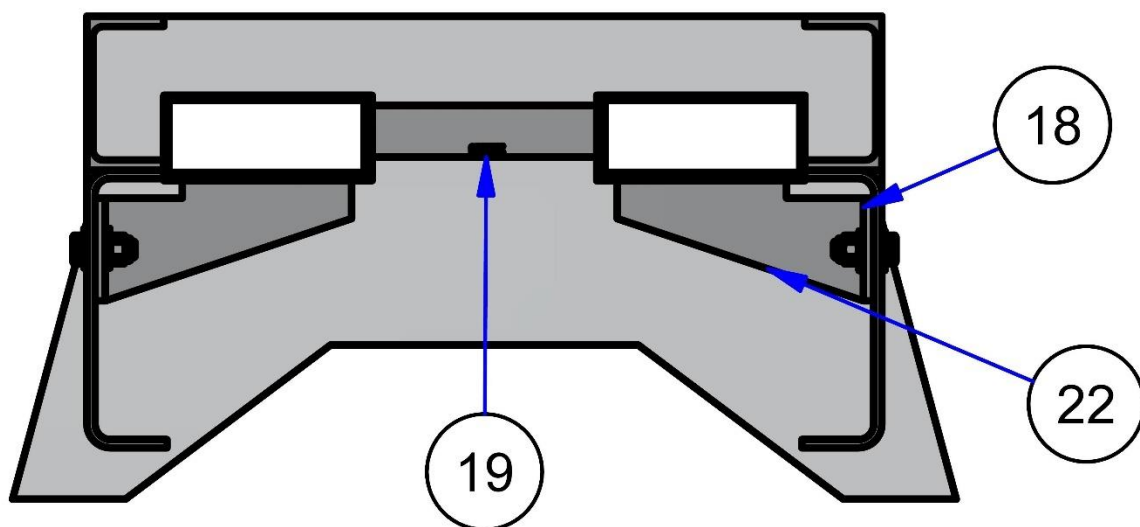


### 3.3 Box Section and Gussets

1. Check the length of the 100 x 50 box section cross member; it may require cutting to fit the width inside your fork slippers
2. Tack weld the fork slippers into position parallel to the chassis and bed, ensuring a minimum of 60 mm protrudes through the back plate
  - a. This dimension may need to be increased to prevent the forklift mast colliding with the rear door catches



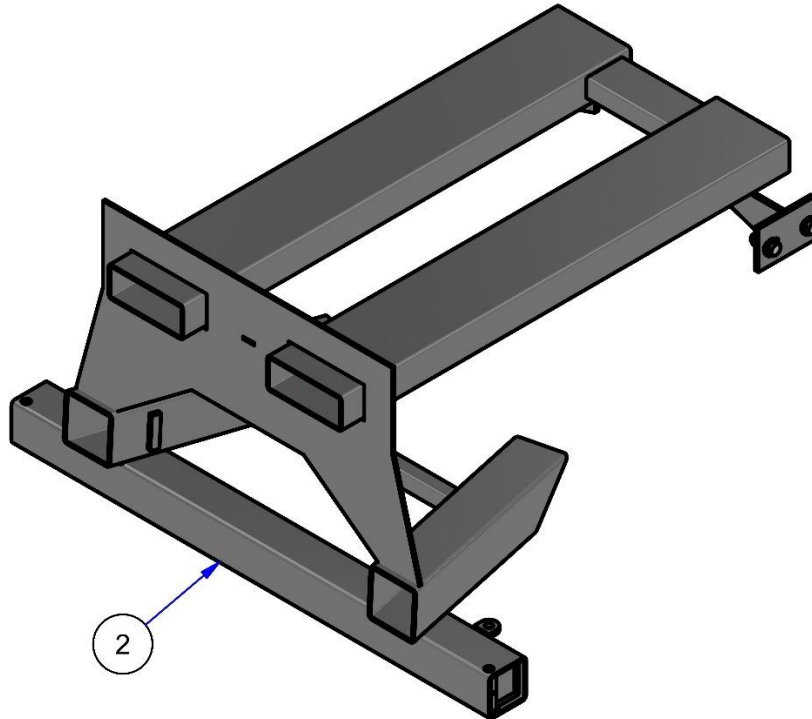
*Figure 5 (Chassis and Gussets)*



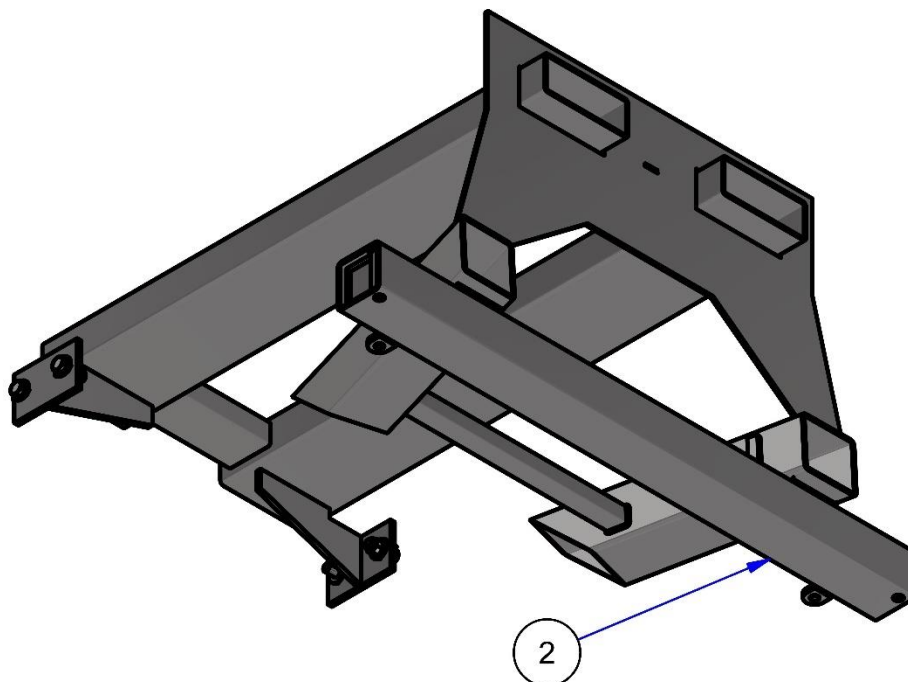
*Figure 6 (Chassis and Gussets Rear View)*

### 3.4 Underrun Bar Assembly

1. Jack the prefabricated centre underrun bar assembly into position.
2. Tack weld it to the back plate as illustrated in Figures 7 and 8
3. Ensure the bottom of the underrun bar sits at a 90-degree angle to the back plate
  - a. This will create a 3-degree angle for the leg rests



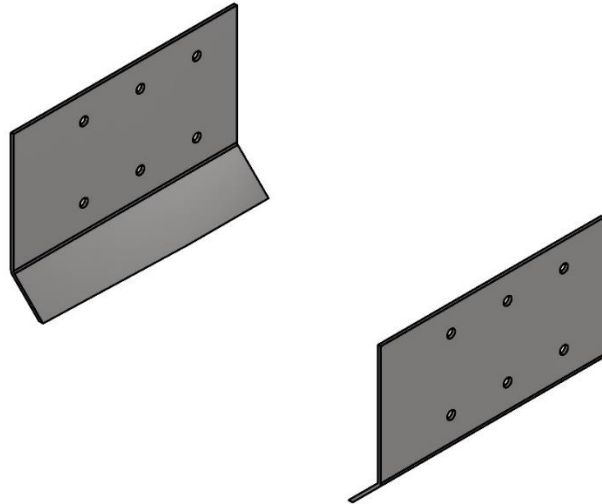
*Figure 7 (Underrun Bar Top View)*



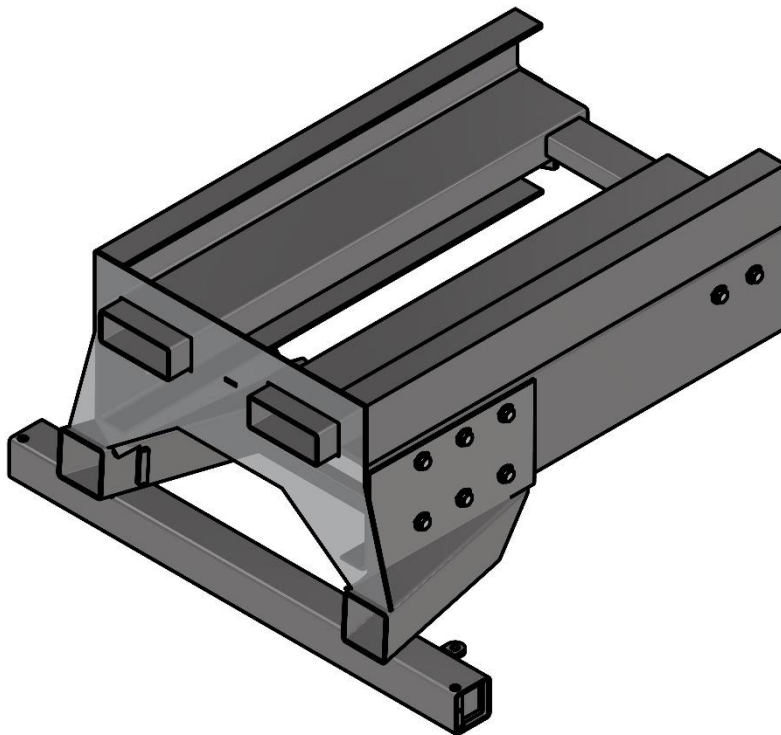
*Figure 8 (Underrun Bar Bottom View)*

### 3.5 Side Plates

1. Predrill 6 x 18.00 mm diameter holes in the side plates
  - a. Check manufacturer recommendations for hole spacing
2. Position the side plates against the chassis and back plate, then tack in place
3. Drill through the truck chassis, if needed, to align with the side plate holes
4. Secure the side plates with M16 bolts and fully weld them in position



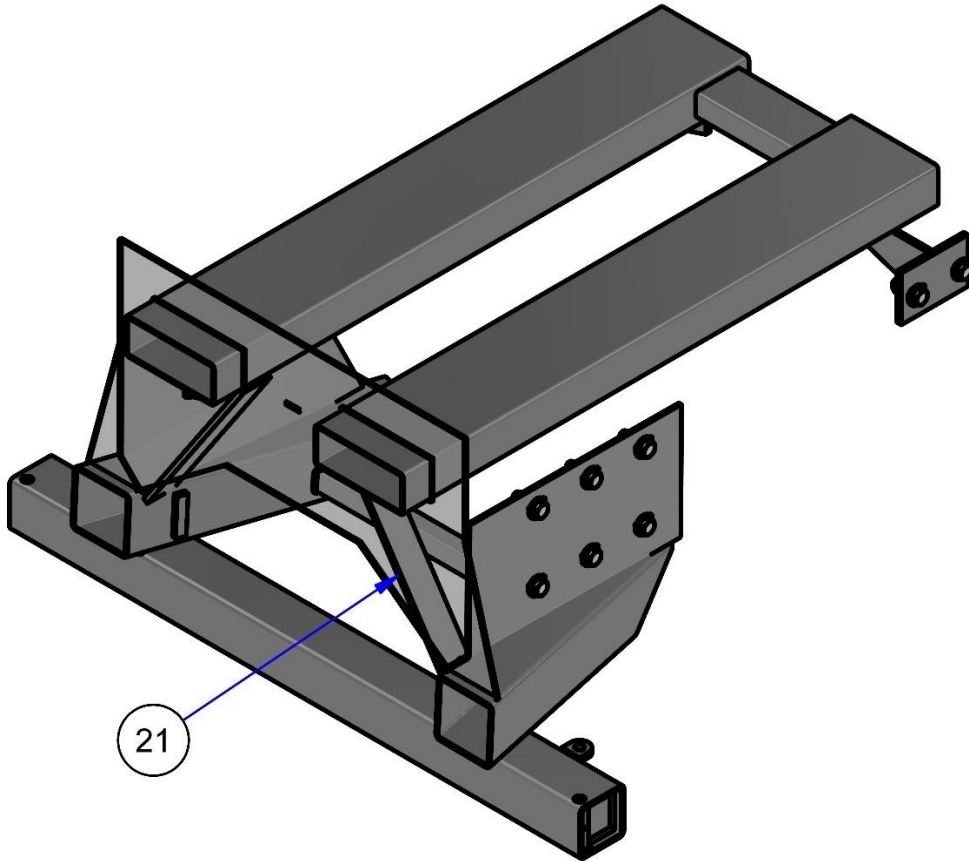
*Figure 9 (Predrilled Side Plates)*



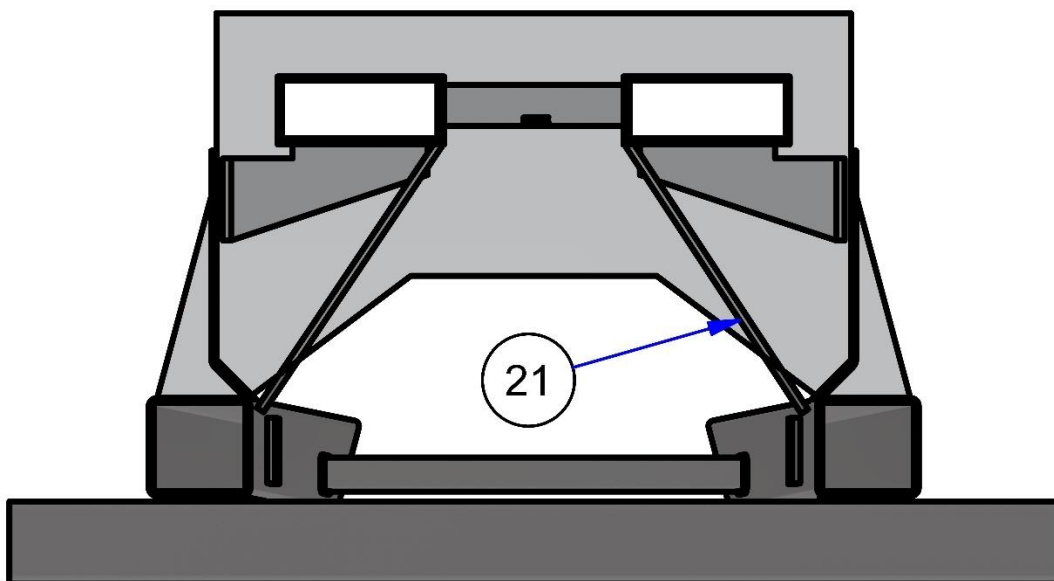
*Figure 10 (Side Plates Secured to Chassis)*

### 3.6 60 X 10 Flat Bars

1. There A length of 60 x 10 flat bar is supplied with the kit.
2. Measure and cut two pieces to size, then weld them to the rear of the back plate as shown in Figures 11 and 12



*Figure 11 (60 x 10 Flat bars)*



*Figure 12 (60 x 10 Flat bars Side View)*

### 3.7 Cut to Size Supports

1. Cut two 100 x 100 box section uprights (Item 6) to suit then weld in position as illustrated Figure 13 and 14

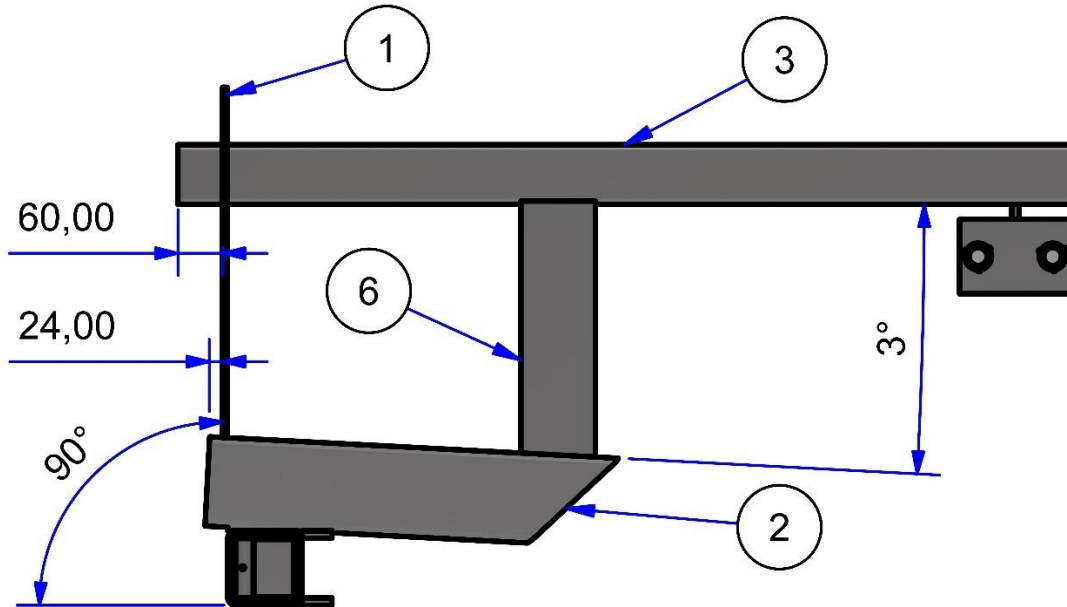


Figure 13 (Box Section Supports with Angles)

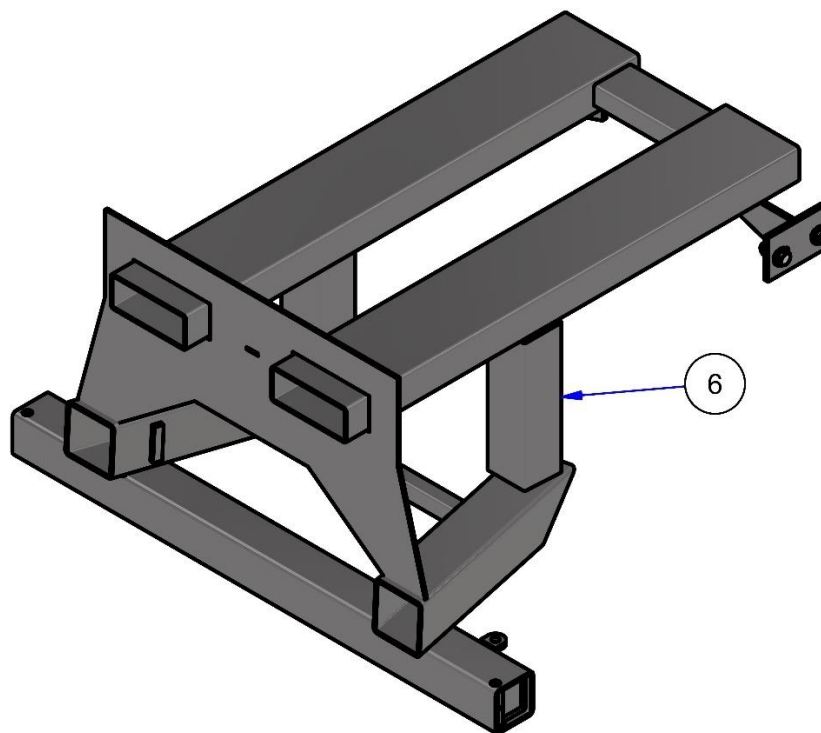
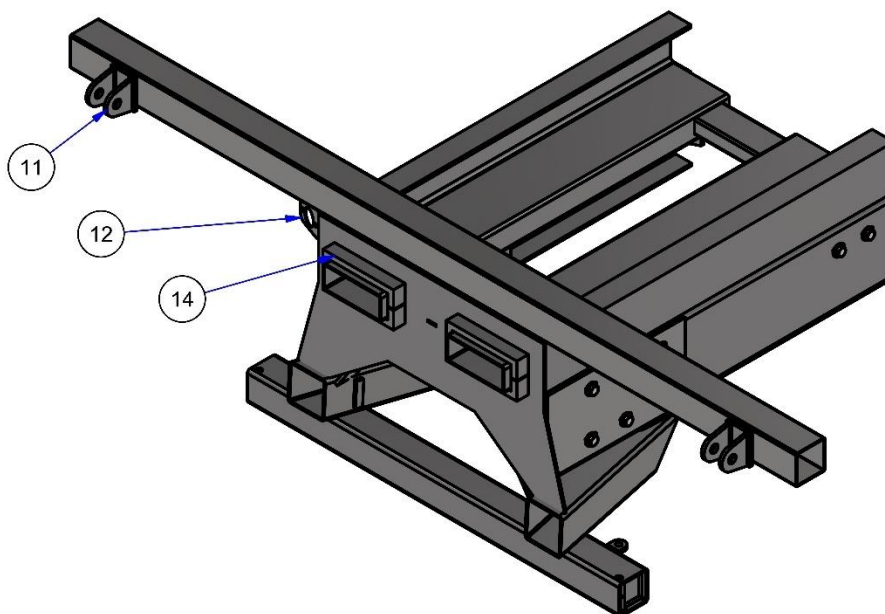


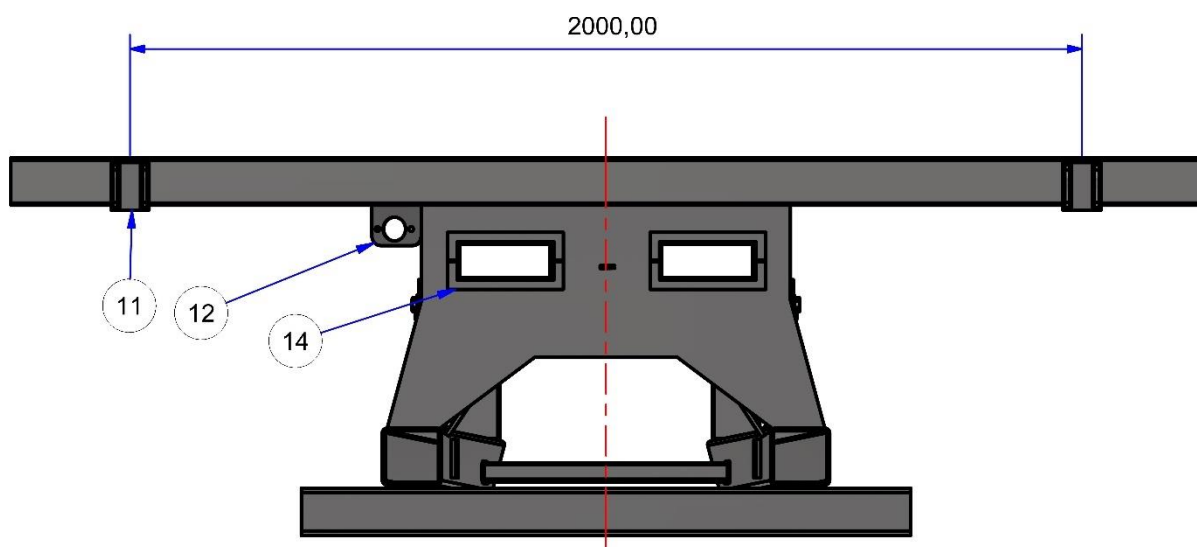
Figure 14 (Box Section Supports)

### 3.8 Ancillaries

1. Weld on ancillary components shown in Figure 15 to their designated positions
  - a. This includes chain brackets, lighting socket plate, and the fork slipper reinforcing profiles
2. The chain brackets should be welded on 2000 mm apart ensuring they are centred
3. Weld the Suzie socket bracket (Item 13) in an appropriate location
  - a. Ensure it does not obstruct anything when the forklift is mounted
  - b. Wire the Suzie cable according to the instructions provided in Section 5
4. Check all joints on the mounting are fully welded, where possible



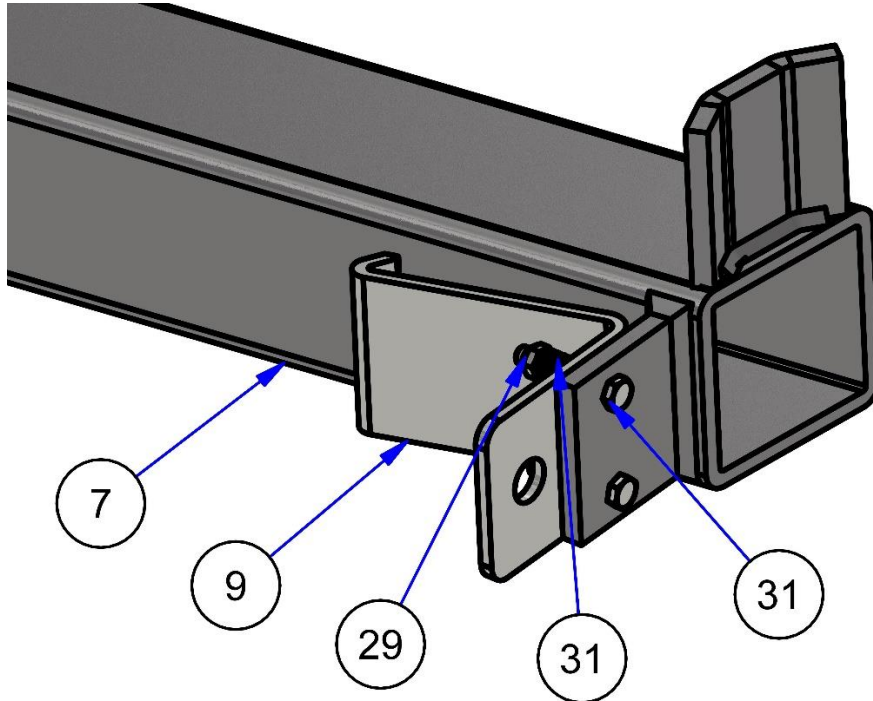
**Figure 15 (Ancillaries)**



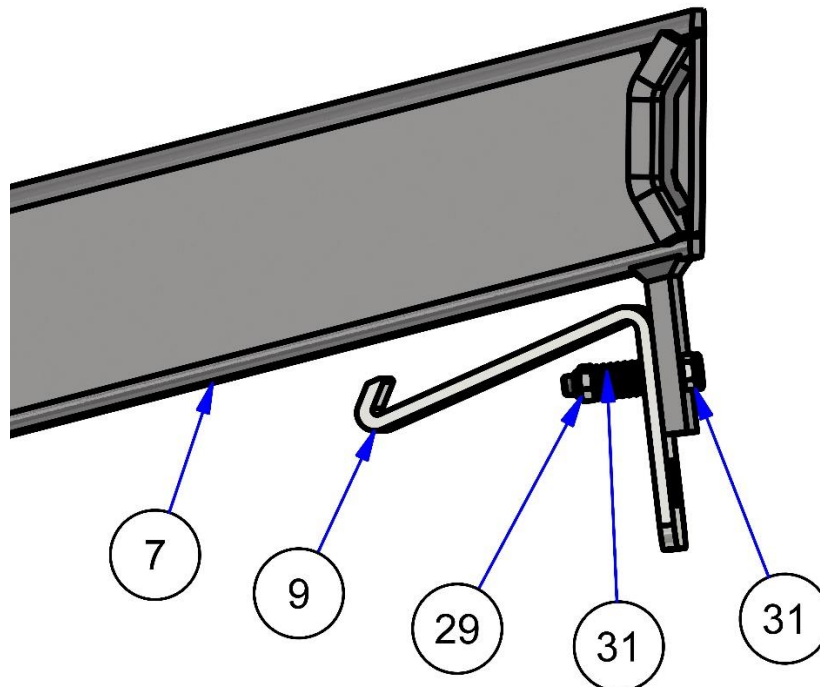
**Figure 16 (Ancillaries)**

### 3.9 Pull-Out Legs

- Bolt the leg retaining catches onto the pull-out legs using the provided M8 x 50 bolts and Nylock nuts
- Position the springs as shown in the diagram



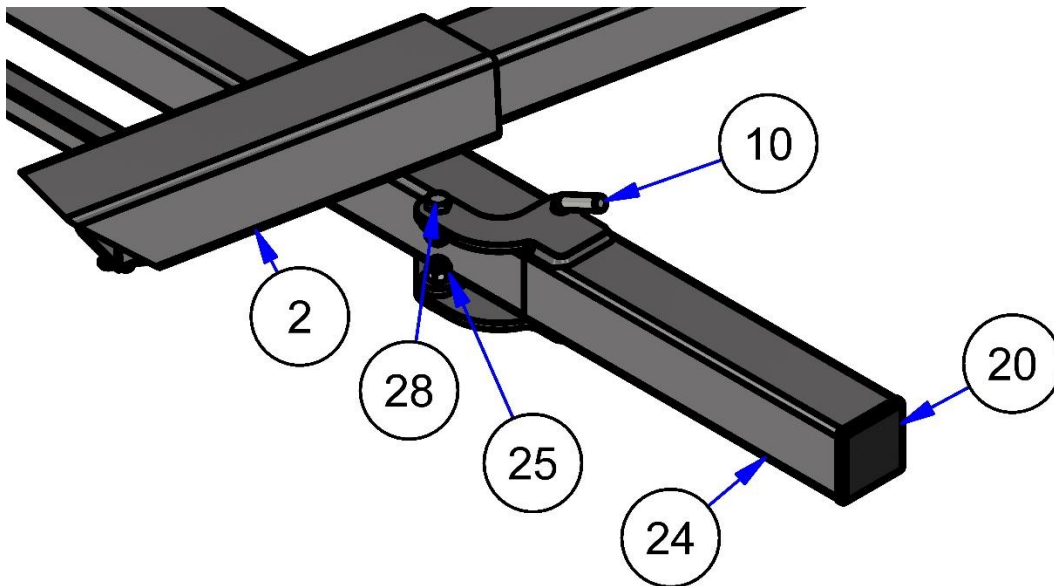
*Figure 17 (Pull-out Leg)*



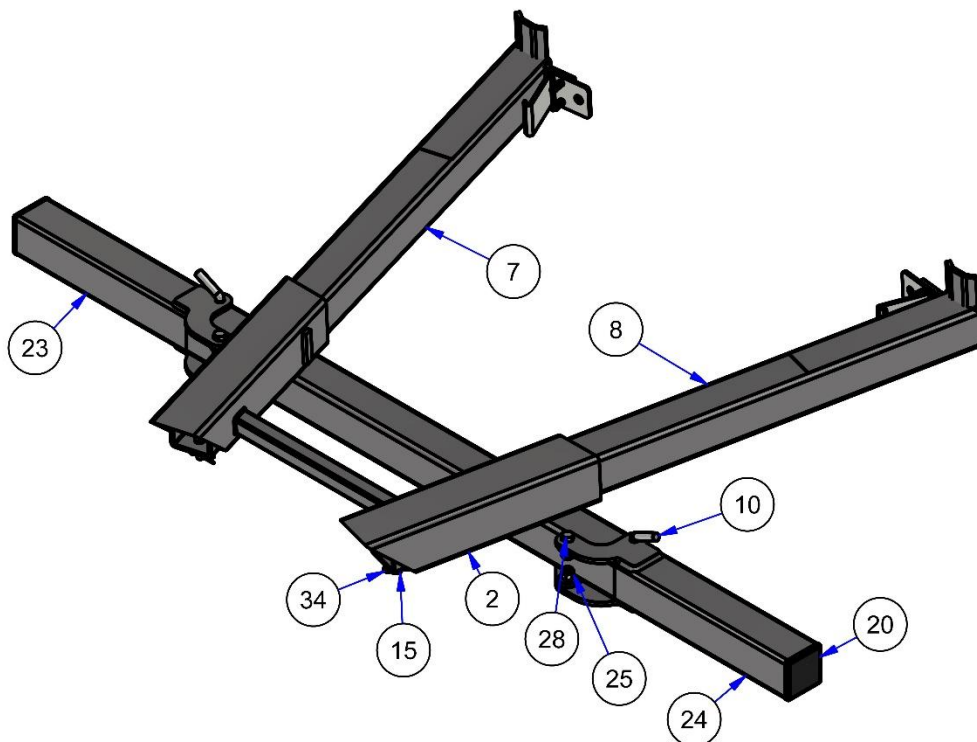
*Figure 18 (Pull-out Leg Top View)*

### 3.10 Underrun Bar

1. Attach the taillight clusters onto the folding underrun bars
2. Bolt Items 23 and 24 onto the underrun bar centre (Item 2b) using the four M16 nuts and bolts as shown in Figure 19
3. Ensure Items 1 and 2 can pivot freely
4. Insert the underrun pins (Items 10) and the R-clips (Items 34) to lock the underrun bar in the desired position

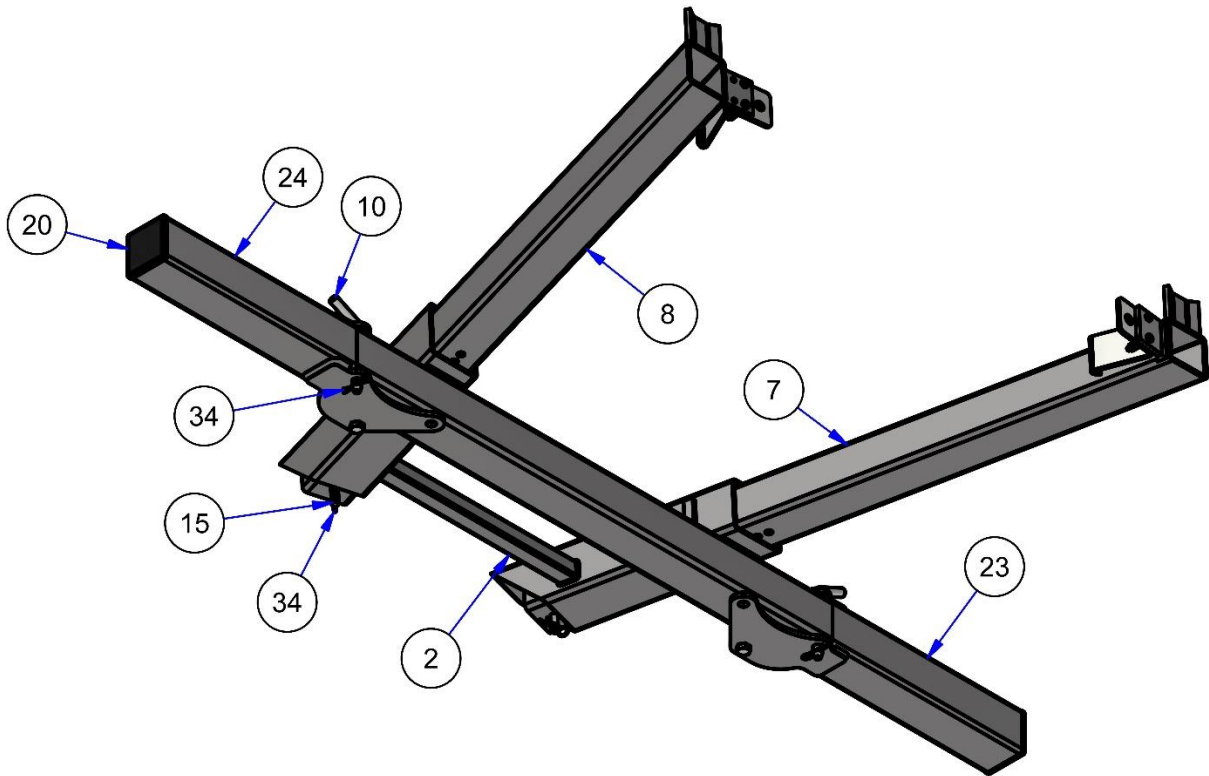


*Figure 19 (Underrun Bar Assembly)*



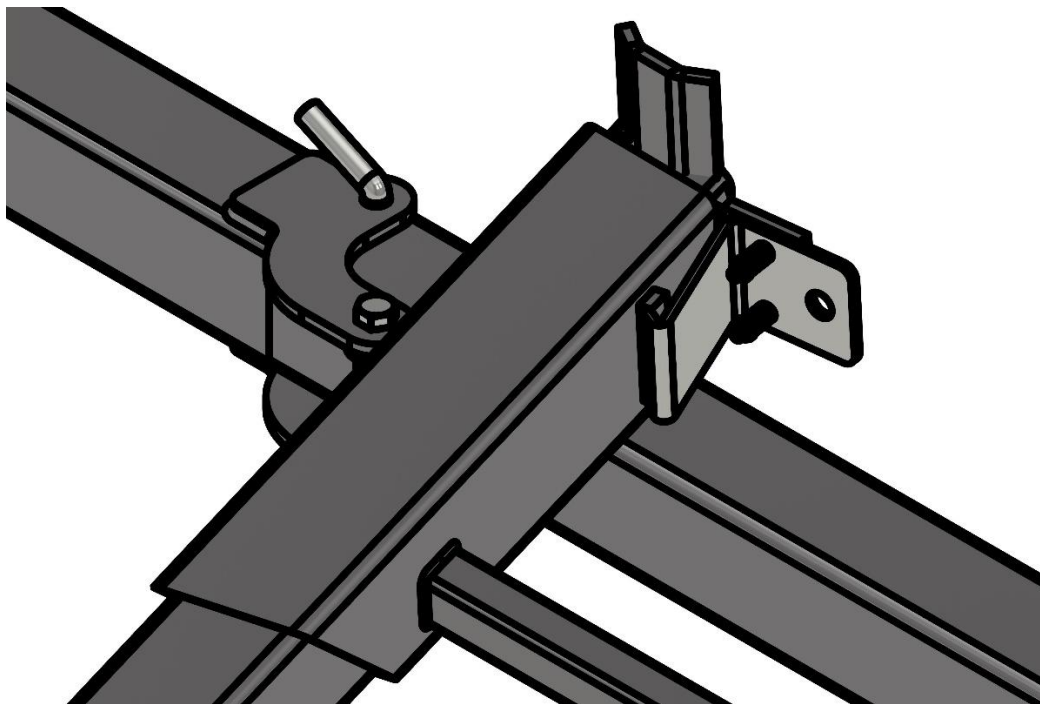
*Figure 20 (Pull Out Leg Top View)*





**Figure 21 (Pull Out Leg Bottom View)**

1. To open and close the pull-out legs use the leg pull handle
2. The pull-out legs lock in the closed position by latching onto the raised flat on the underrun bar assembly



**Figure 22 (Close Up Latch Assembly)**

## 4 Mounting the Forklift

---

Once the mounting frame is fully welded, follow these steps to mount the forklift onto the trailer:

1. Approach the rear of the trailer slowly with the mast extended and forks positioned to suit the mounting kit
2. Drive slowly forward until the forks are tight with the back of the trailer
3. Tilt the mast rearward to raise the rear wheel
4. Lower the forks using the lift lever until the bottom of the machine is higher than the pull-out legs
5. Retract the carriage fully, this will bring the wheels of the forklift under the trailer
6. Move the carriage so that approximately 40 mm (1.5 inches) of chrome rod is visible from the end of the cylinder
7. Use the leg pull handle to pull both legs out
  - a. Set the length of the pull-out legs by placing the pins (Items X) in the appropriate holes and securing with R-clips
8. Fully retract the mast carriage towards the driver

## 5 Lighting Socket Wiring

Most modern trucks are now equipped with an onboard computer, known as the CAM or telemetric system, which controls the extensive array of electronics, from the windows to the brakes and suspension.

When installing the connection plug (Suzie socket) for the 7-pin socket to rigid trucks for the auxiliary lights of the truck-mounted forklift, it is crucial to avoid damaging the truck's telemetric/CAM system.

**To prevent such damage, the person wiring the mounting kit auxiliary socket must contact the truck manufacturer before cutting into the truck's wiring system, as improper handling can cause extensive and costly damage.**

Some trucks are equipped with special sockets within the chassis specifically for this purpose. For others, it may be necessary to wire the auxiliary lights back to the fuse box, this varies by manufacturer and model. Details on connecting to the wiring system can be found in the bodybuilder's manual or CD provided by most manufacturers. If this information is not available, please contact the manufacturer directly.

Below (Table 4) are the two most common methods to wire the 24V 7-pin 24N socket, with and without a reversing light

*Table 2 (Wiring Colours)*

Type: 24N, ISO:1185 24V Socket			
POS	Wire Colour	With Rev Light	Without Rev Light
1	White	Ground	Ground
2	Black	Reverse	LH side lights
3	Yellow	LH indicator	LH indicator
4	Red	LH/RH stoplights	LH/RH stoplights
5	Green	RH indicator	RH indicator
6	Brown	LH/RH side lights	RH side lights
7	Blue	Fog light	Fog light